

High Sensitivity (-129dBm) Wireless LoRa Module

433Mhz/470MHz; 868Mhz/915MHz

SPECIFICATION

Model No.: DL-LLCC68-S

Version: V1.4



433/470MHz



868/915MHz

Before using this RF module, please pay attention to the following important matters:

This module is an electrostatic sensitive product. Please operate it on an anti-static workbench during installation and testing.

This DL-LLCC68-S module uses an external antenna by default, which is intended to be embedded in your product or application, and does not provide a casing itself. The antenna can be a wire antenna or a standard UHF antenna. You can choose a specific antenna according to the actual situation.

Metal objects and wires should be kept away from the antenna as much as possible. If the product uses a metal shell, be sure to install the antenna outside the metal shell. Otherwise, the RF signal will be seriously attenuated, which will affect the effective distance.

Disclaimer:

This specification is just for your information; all the charts and pictures used in this specification are for reference only. The actual test shall prevail for details. We do not assume any responsibility for personal injury or property loss caused by user's improper operation.

This specification is subject to change due to the continuous improvement and upgrading of the product version, and the latest version specification shall prevail. DREAMLNK reserves the right of final interpretation and modification of all contents in this specification.

| Date | Version | Formulation / Revision of Contents | Approved by |
|------------|---------|---|-------------|
| 2021-1-1 | V1.0 | DL-LLCC68-S Standard Version RF Module | Fagan Xu |
| 2021-9-16 | V1.1 | Revised Pin Definition and Description | Fagan Xu |
| 2021-12-10 | V1.2 | Parameters and Instructions Correction | Fagan Xu |
| 2023-03-15 | V1.3 | Add Metal Shield Version | Fagan Xu |
| 2026-06-16 | V1.4 | Change the product photos, discontinue the old versions | Fagan Xu |

Copyright © Shenzhen DreamLnk Technology Co., Ltd

1. Module Introduction

1.1 Brief Introduction

DL-LLCC68-S is a wireless module designed based on **Semtech's** radio frequency chip **LLCC68**. It mainly adopts a new generation of LoRa™ modulation technology for ultra-long-distance spread spectrum communication. This LoRa module is compact in size, and has the characteristics of ultra-low receiving power consumption, strong anti-interference ability, and longer transmission distance than traditional modulation methods. It can be widely used in various wireless communication fields of the Internet of Things.

DL-LLCC68-S RF module has high receiving sensitivity of $-129\text{dBm}@LoRa$, ultra-low receiving current and dormant current, the transmit power can be configured through software, and the maximum power can reach $+22\text{dBm}$. Compared with traditional modulation technology, LoRa™ modulation technology has obvious advantages in anti-blocking and selection, which solves the problem of distance, anti-interference and power consumption that traditional design schemes cannot take into account at the same time.

1.2 Features

- Support (G)FSK, LoRa™ and other modulation methods;
- The chip supports a frequency range of 150~960MHz;
- Recommended frequency: 433/470M RF Module \implies 300~510MHz;
868/915M RF Module \implies 800~960MHz;
- The working voltage is 3.3V, the maximum output transmitting power is $+22\text{dBm}$, and the maximum working current is 130mA;
- It has low power consumption characteristics in the receiving state, the minimum receiving current is 5.3mA, and the standby current is 1uA;
- High receiving sensitivity: $-129\text{dBm}@LoRa@1.76\text{Kbps}$;
- Support fast Channel Activity Detection (CAD);
- Support spreading factor: SF5/SF6/SF7/SF8/SF9/SF10/SF11;
- Supported bandwidth: 125kHz, 250kHz, 500kHz

Note: BW = 125kHz supports SF5-SF9

BW = 250kHz supports SF5-SF10

BW = 500kHz supports SF5-SF11 (please refer table 4 to know more)

1.3 Typical Application

- Wireless automatic meter reading (water meter, electric meter, gas meter)
- Ultra-long distance data communication
- Smart home system
- Intelligent security monitoring
- Smart building
- Industrial controllers, sensors
- Agricultural automation solutions
- Intelligent parking system
- Automotive industry applications
- Supply chain logistics

2. Technical Parameter

| Parameter | Min. | Typical | Max. | Unit | Remarks |
|--|------|------------------|------|------|--|
| Operating Conditions | | | | | |
| Working voltage & IO voltage range | 1.8 | 3.3 | 3.7 | V | To ensure maximum chip power, stable voltage should $\geq 3.1V$ |
| Working temperature range | -40 | 25 | 85 | °C | |
| Current Consumption | | | | | |
| Receiving current | 4.5 | 5.2 | 5.4 | mA | Adopts CAD working mode, Can effectively reduce the overall working current |
| Transmission current @433MHz | | 115 90 75 | | mA | @433MHz @ DCDC ANT Out +22dBm ANT Out +21dBm ANT Out +17dbm |
| Transmission current @868MHz @915MHz | | 125 110 98 | | mA | @868MHz @915MHz @DCDC ANT Out +22dBm ANT Out +20dBm ANT Out +17dbm |
| Standby current | 0.4 | 1.2 | 1.5 | uA | Save by register |
| RF Parameters | | | | | |
| Recommended Frequency (Ensure best performance) | 300 | 433/470 | 510 | MHz | @433MHz/470Mhz RF module |
| | 779 | 868/915 | 960 | MHz | @868MHz/915Mhz RF module |

| | | | | | |
|--------------------------------------|------|------|------|------|---|
| Transmit power range | -9 | 22 | 22 | dBm | Table 13-40 in Data Sheet: SetTxParams SPI Transaction |
| LoRa Receiving sensitivity (Max.) | | -129 | | dBm | @BR_L=1.76Kbps SF9, BW_L = 125 kHz |
| FSK Receiving sensitivity (Max.) | | -125 | | dBm | @BR_F = 0.6 kb/s, FDA = 0.8 kHz, BW_F = 4 kHz |
| FSK Rate range | 0.6 | | 300 | Kb/s | |
| LoRa Rate range | 1.76 | | 62.5 | Kb/s | @Payload rate Min. for SF9, BW_L = 125 kHz Max. for SF5, BW_L = 500 kHz |

Table 1: Technical Parameter

3. Pin Definitions

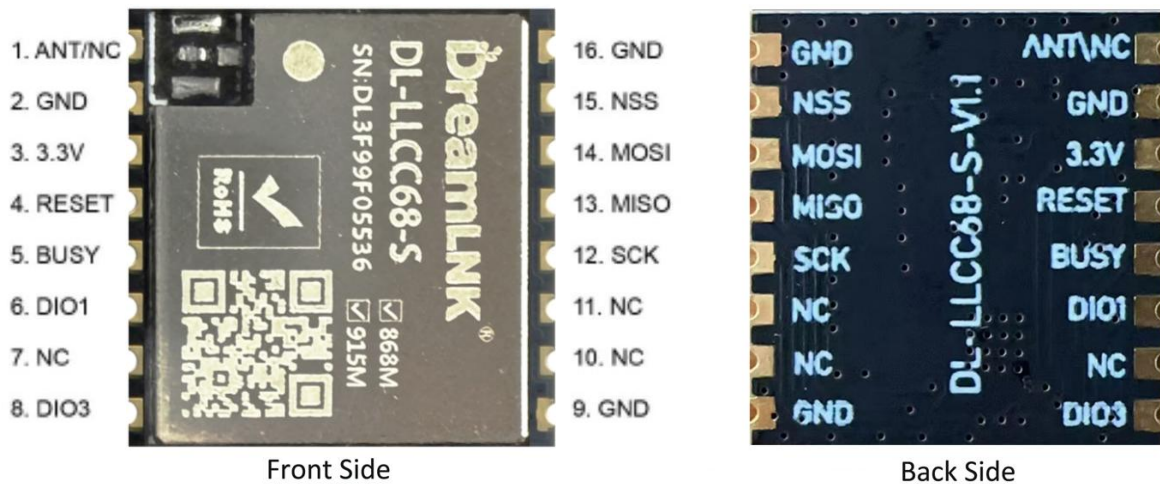

Front Side

Back Side

| No | Definitions | | Description |
|----|-------------|-------|--|
| 1 | ANT/NC | AI/AO | Antenna interface, 50Ω impedance, ground and via hole |
| 2 | GND | PWR | Reliable grounding |
| 3 | 3.3V | PWR | To maximize the chip function, 3.3V stable voltage is recommended |
| 4 | RESET | I | Reset to initialize the chip, for an increased stability. High level as defaulted, while low level to reset the chip |
| 5 | BUSY | O | The internal status indicator pin of the chip, which needs to be connected to the GPIO of the master MCU |
| 6 | DIO1 | IO | Digital I/O 1 port, Configurable via software |
| 7 | NC | | No connection |

| | | | |
|----|------|-----|---|
| 8 | DIO3 | IO | Digital I/O 3 port, Configurable via software |
| 9 | GND | PWR | Reliable grounding |
| 10 | NC | | No connection |
| 11 | NC | | No connection |
| 12 | SCK | I | SPI Serial Clock Input |
| 13 | MISO | O | SPI Master Input Slave Output |
| 14 | MOSI | I | SPI Master Output Slave Input |
| 15 | NSS | I | SPI Chip Select Input |
| 16 | GND | PWR | Reliable grounding |

Table 2: Pin Definitions

4. Module Size & SMT

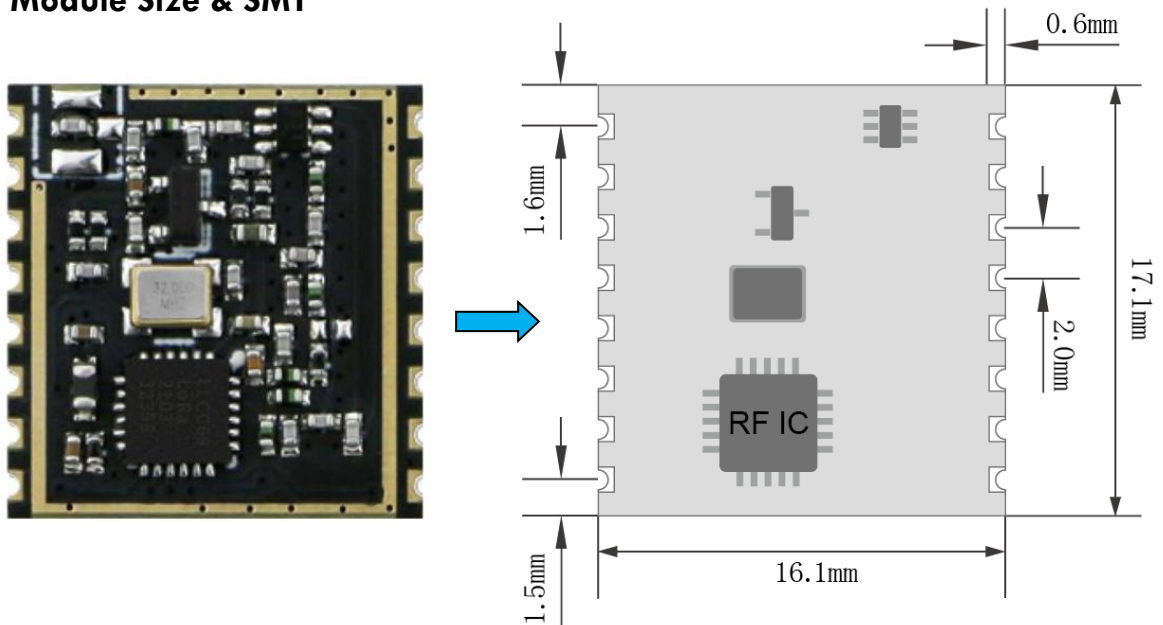

Please apply for module packaging from our technical support: SMT patch package, DIP in-line package file (refer to schematic diagram)

Package files format description:

- * .ASC format can be opened with Protel99se;
- * .DXF format can be opened with CAD;
- * .PCB format can be opened with PADS software;

Module packaging: SMT placement (steel mesh thickness $\geq 1.2\text{mm}$)

5. Application Connection Diagram

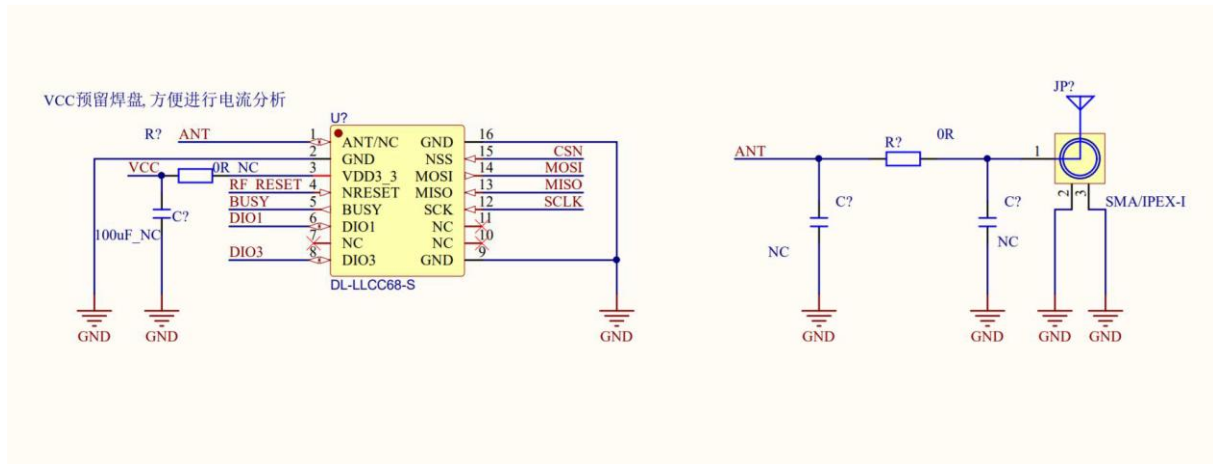

Note: This diagram is just for your reference only. If you have any question, please contact us for more help.

6. Circuit Design

6.1 Power Supply Design

- Please pay attention to the power supply voltage of the device, exceeding the recommended voltage range may cause function abnormally and permanently damage;
- Try to use a DC stabilized power supply, and the power ripple coefficient should be as small as possible; the power load when transmitting the maximum power needs to be also considered;
- The RF module needs to be grounded reliably, and try to reduce the loops in PCB layout (especially the loop between ANT Pin and GND Pin should be as short as possible); a good grounding can achieve better performance and reduce the impact of RF on other sensitive devices.

6.2 RF Routing Design

- The module should be far away from RF interference sources, such as high-frequency circuit transformer, and please do not directly route at the lower layer of the RF module. Otherwise, the receiving sensitivity may be affected;
- When using the on-board antenna, the antenna needs to be clear on both sides, and the ground (copper foil) should not be too close to the antenna at the same time, otherwise it will absorb the radiated energy;
- Route 50Ω impedance line, lay the ground and add more via holes around it
- If there is enough space on your PCBA, please reserve a π -type matching circuit, and it needs to be placed as close to the chip end as possible, please make it grounded and add via holes around it. Do remember to

connect it through a OR resistor, otherwise the antenna will open circuit; SMA ANT circular through-hole requires clearance treatment

6.3 Antenna Design

- There are many types of antennas, please choose the appropriate antenna according to your needs;
- Choose a suitable position to place the antenna, according to the antenna polarity. And it is recommended to be vertically upward;
- There should be no metal objects in the antenna radiation path, otherwise the transmission distance will be affected (such as a closed metal casing).

6.4 LLCC68 I/O design

- When doing the hardware design, for the data packet mode (SPI transmission), the general SPI interface, RST, BUSY, DIO1 interfaces should be lead out to the GPIO of the MCU;
- DIO1 and DIO3 can be used to map the interrupt events of the chip via software, and we can query the interrupt source through functions, but not every mode is available. For details, please refer to the Chip Manual: 13.3 DIO and IRQ Control Functions & Chip Manual: Table 13-29: IRQ Registers (Interrupt Source)
- Regarding the electronic switch of the transceiver mode

The chip DIO2 is designed by hardware as the switch control of antenna switching (so there is no related TXEN RXEN pin, which is convenient for software and hardware design). In order to facilitate and simplify the software control, the DIO2 of the chip is used to automatically control the switching of the switch tube through the circuit inside the module, so when writing the software, please note that you need to use SetDIO2AsRfSwitchCtrl to enable automatic control.

7. Software Debugging Process

7.1 Transplant HAL interface (SPI interface, and pay special attention to verify that the reset function is normal);

7.2 Familiar with the chip register table and related API (Refer data sheet: 12.1 Register Table);

7.3 Enable DIO2 for internal automatic electronic switch control SetDIO2AsRfSwitchCtrl;

7.4 Make two verification PCB boards, according to the Demo Program, to complete the communication verification of transmitting and receiving;

7.5 It is recommended to use LoRa modulation. After communication normally set up, you need to optimize the modulation parameters, and change the spreading factor, bandwidth and other parameters according to your needs to control the code transmission time (related to the symbol time) and communication distance;

7.6 It can be set by the SetModulationParams function, and the commonly used debugging parameters are as follows:

| | |
|------------------------------|---|
| Modulation Bandwidth (BW_L) | The higher the BW, the faster the modulation rate, but the larger the signal bandwidth will reduce the sensitivity of the receiver |
| Spreading Factor (SF) | The higher SF can increase the sensitivity of demodulation and increase the distance; the disadvantage is that it will greatly increase the transmission time |
| The Coding Rate (CR) | In the case of severe interference, it can increase the anti-interference, but the disadvantage is that the coding efficiency will be reduced and the baud rate will slow down. Under normal circumstances, the default CR = 4/5 can be used. |
| Low-Rate Optimization (LDRO) | When a single symbol time is equal to or greater than 16.38ms, low-rate optimization needs to be turned on |

Table 3: Commonly Used Debugging Parameters

7.7 The maximum transmit power can be +22dbm, to ensure the largest link budget;

7.8 If low power consumption is required, CAD working mode (sleep-detection signal-sleep) can be used in the software to achieve low power consumption

Please refer Data sheet: 6.1.5 LoRa® Channel Activity Detection (CAD);

7.9 In LoRa mode, the corresponding table between the symbol time sent by the spreading factor and the bit rate of the actual payload is as follows:

| SF \ BW | 125 kHz | | 250 kHz | | 500 kHz | |
|---------|------------------|-------------|------------------|-------------|------------------|-------------|
| | Symbol time (ms) | Rate (kbps) | Symbol time (ms) | Rate (kbps) | Symbol time (ms) | Rate (kbps) |
| 5 | 0.26 | 15.63 | 0.13 | 31.25 | 0.06 | 62.50 |
| 6 | 0.51 | 9.38 | 0.26 | 18.75 | 0.13 | 37.5 |
| 7 | 1.02 | 5.47 | 0.51 | 10.94 | 0.26 | 21.88 |
| 8 | 2.05 | 3.13 | 1.02 | 6.25 | 0.51 | 12.5 |
| 9 | 4.10 | 1.76 | 2.05 | 3.52 | 1.02 | 7.03 |
| 10 | N/M | | 4.10 | 1.95 | 2.05 | 3.91 |
| 11 | N/M | | N/M | | 4.10 | 2.15 |

Table 4: Symbol time and bit rate

Note: The payload data refers to the data you actually transmit, but the actual transmission time includes not only the payload, but also the preamble, the header, its encoding rate, and the check digit of the payload.

Collective reference: 6.1.3 LoRa® Frame

7.10 About frequency settings:

To ensure the maximum performance of the RF module, it is necessary to select the correct frequency band RF module. Meanwhile, the recommended frequency range for software settings are as follows:

430~440 MHz, 470~510 MHz, 779~787 MHz, 863~870 MHz, 902~928 MHz

8. Welding Operation Guidance

8.1 Reflow Soldering Curve Chart

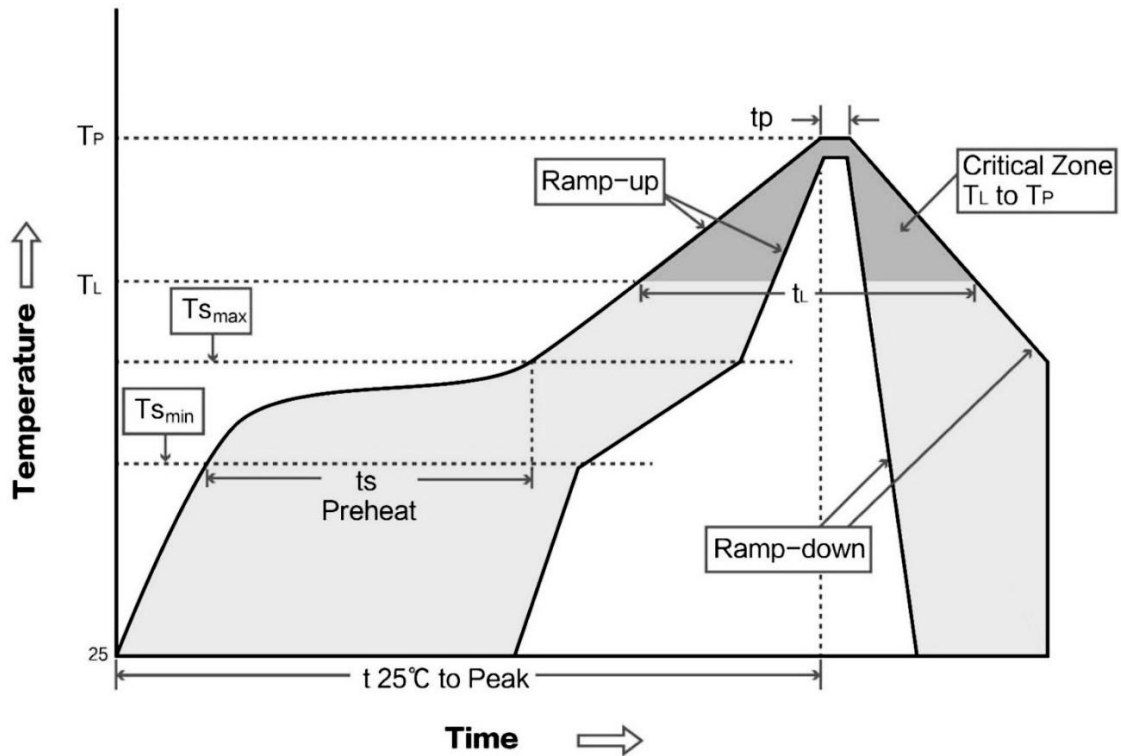





8.2 Reflow Soldering Temperature

| IPC/JEDEC J-STD-020B the condition for lead-free reflow soldering | Big size components (thickness ≥ 2.5 mm) |
|--|---|
| The ramp-up rate (T_L to T_P) | 3°C/s (max.) |
| Preheat Temperature | |
| - Temperature Minimum ($T_{S_{min}}$) | 150°C |
| - Temperature Maximum ($T_{S_{max}}$) | 200°C |
| - Preheat Time (t_s) | 60~180s |
| Average ramp-up rate ($T_{S_{max}}$ to T_P) | 3°C/s (Max.) |
| - Liquidous temperature (T_L) | 217°C |
| - Time at liquidous(t_L) | 60~150 second |
| Peak Temperature (T_P) | 245+/-5°C |

9. Notice for module application

- (1) This module is an electrostatic sensitive product. Please operate on an anti-static workbench during installation and testing;
- (2) When installing the module, ensure that nearby objects keep a sufficient safe distance from the module to prevent short-circuit damage;
- (3) Never allow any liquid substance to come into contact with this module, and this module should be used in a dry environment;
- (4) Please Use an independent voltage stabilizing circuit to supply power to this module, and avoid sharing with other circuits. The tolerance of the power supply should not be less than 5%.
- (5) The indicators of this module are accord to commonly used international standard. If special certifications needed, we can adjust certain indicators according to your needs.

10. Model Selection Table:

| Model No. | Picture | Feature | Frequency |
|------------------|---|-------------------|-----------|
| DL-LLCC68-S-433S |  | With Metal Shield | 433MHz |
| DL-LLCC68-S-470S |  | With Metal Shield | 470MHz |
| DL-LLCC68-S-868S |  | With Metal Shield | 868MHz |
| DL-LLCC68-S-915S |  | With Metal Shield | 915MHz |

11. Contact us

Shenzhen DreamLnk Technology Co., Ltd

★ Data collection, Smart home, Internet of Things applications, Wireless remote control technology, Remote active RFID, Antennas ★

Office: 601-603, Bldg C, Zone A, Huameiju Plaza, Xihu Rd., Bao'an District, Shenzhen 518101, China

Factory: Huazhi Innovation Valley, No. 7 Yuhua Street, 138 Industrial Zone, Tangxia Town, Dongguan, Guangdong, China

TEL.: +86-755-29369047

FAX: +86-755-27844601

Mobile: +86-13760215716

E-mail: james@dreamlnk.com

Web. (CN): www.dreamlnk.com

Web. (EN): www.iot-rf.com